

**VO** Series



油潤滑旋片式真空泵

***Oil Lubricated Rotary Vane  
Vacuum Pump***





## VO - 20 / 25 油潤滑旋片式真空泵 / Oil Lubricated Rotary Vane Vacuum Pump

油潤滑旋片式真空泵，流量從 20 至 26.5 m<sup>3</sup>/hr，絕對真空 2mbar（絕對值）。特別是安裝在小型真空包裝機。法蘭式電機，轉子兩側裝有軸承及空氣冷卻，內置過濾篩網，真空逆止閥和油霧過濾器。法蘭式電機符合 DIN EN60034，具有 IP54 防護和絕緣等級 F。

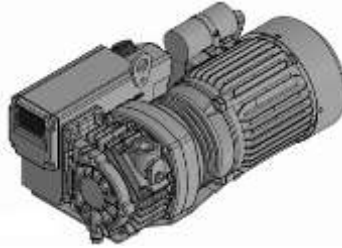

Oil lubricated rotary vane vacuum pump with capacities ranging from 20 to 26.5 m<sup>3</sup>/h and an ultimate vacuum of 2 mbar (abs.). Designed especially for installation in small vacuum packaging machines. Flange motor, bearings on both sides of the rotor, air cooling. Fitted as standard with fine mesh filter, vacuum non-return valve and oil separator. Flange mounted motors comply with DIN EN 60034, have IP54 protection and insulation class F.

### 性能曲線圖 / Performance Curve

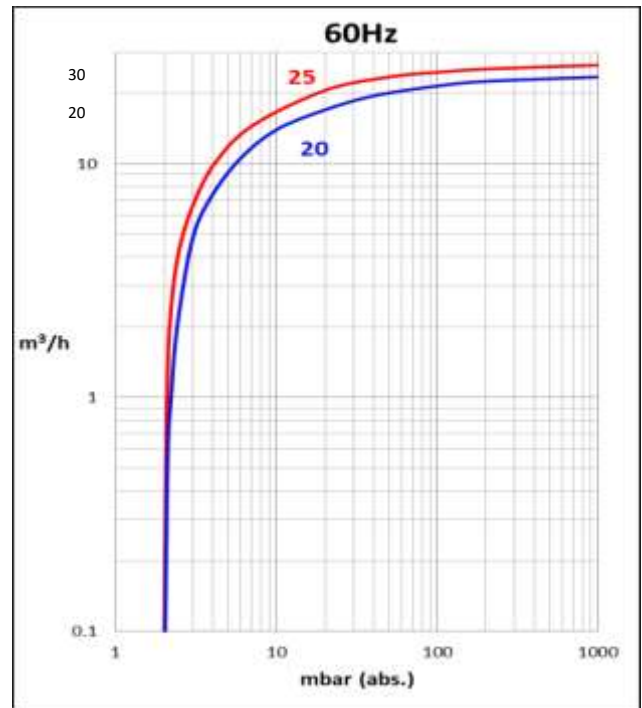
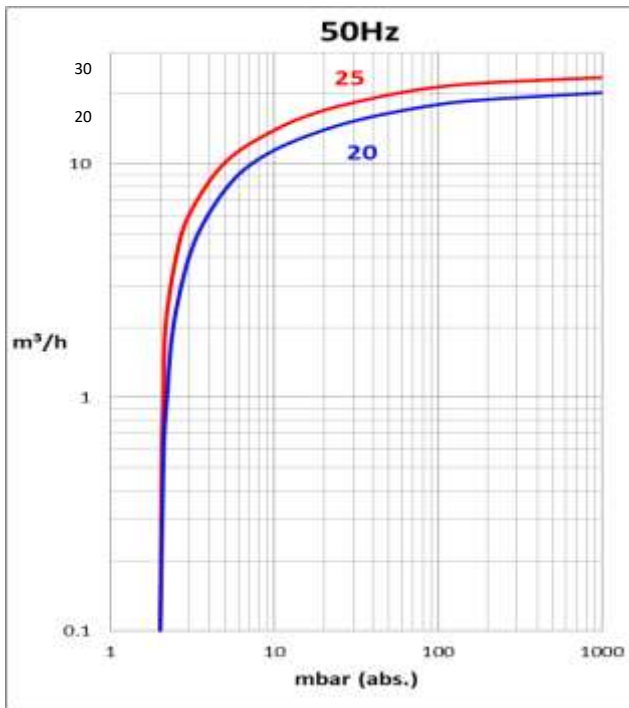

VO		20		25		
頻率 Frequency	Hz	50 Hz	60 Hz	50 Hz	60 Hz	
額定流量 Nominal capacity	m <sup>3</sup> /h	20	24	22.5	26.5	
絕對真空 Ultimate partial pressure	mbar (abs.)	2				
電機類型 Motor version		3~	50Hz - 200~240 / 346~415V / 60Hz - 220~275 / 380~480V			
		1~	230 V ± 10%			
電機功率 Motor rating	kW	3~	0.75	0.85	0.75	0.85
		1~	0.75	0.85	0.75	0.85
電流 Current	A	3~	3.70/2.14	3.90/2.25	3.70/2.14	3.90/2.25
		1~	5.8	6.5	5.8	6.5
轉速 Speed	min <sup>-1</sup>		2830	3350	2830	3350
平均噪音值 Average noise level	dB(A)		63	64	62	66
最大重量 Maximum weight	kg		3~21.5 / 1~23			
油量 Oil capacity	l		0.35			



# VO - 20 / 25 油潤滑旋片式真空泵 / Oil Lubricated Rotary Vane Vacuum Pump

## 尺寸圖 / Dimensions (mm)

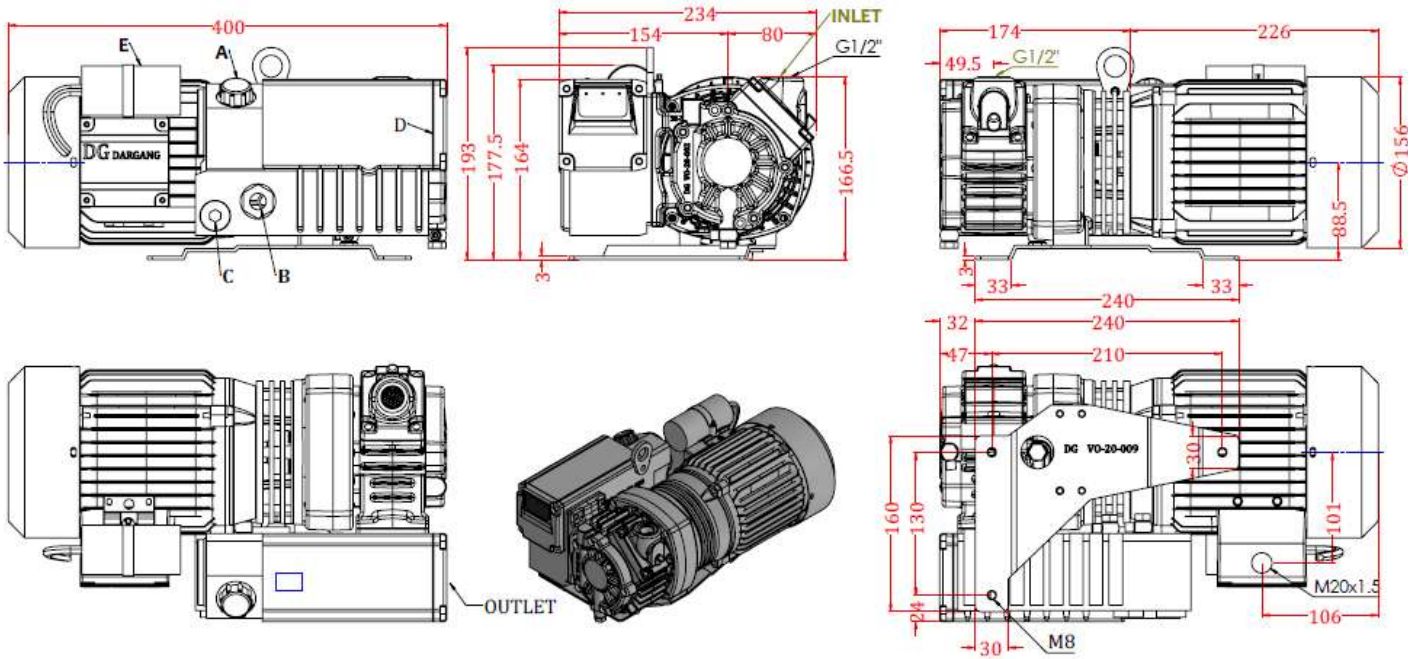

<b>A</b>	注油口 Oil filling point	<b>D</b>	油霧分離器 Oil separator
<b>B</b>	油位鏡 Oil check	<b>E</b>	電容器（單相） Capacitor for 1 phase
<b>C</b>	排油口 Oil drain point		

我們保留調整數據的權利，尺寸和電流值會因不同的電機而與數據表不同。  
 We reserve the right to alter technical information. The dimensions and the current drawn can differ when compared with the data list, depending on the motor type.



## VO - 50 / 75 油潤滑旋片式真空泵 / Oil Lubricated Rotary Vane Vacuum Pump

油潤滑旋片式真空泵，流量從 50 至 84 m<sup>3</sup>/hr，絕對真空 0.1mbar（絕對值）。法蘭式電機，轉子兩側裝有軸承及空氣冷卻，內置過濾篩網，真空逆止閥，氣鎮閥，保護罩和油氣分離器。葉片採用鋁合金材質，壽命長，汽缸兩側採用 O 型密封環。法蘭式電機符合 DIN EN60034，具有 IP54 防護和絕緣等級 F



Oil lubricated rotary vane vacuum pump with capacities ranging from 50 to 84 m<sup>3</sup>/h and an ultimate vacuum of 0.1 mbar (abs.). Flange motor, bearings on both sides of the rotor, air cooling. Fitted as standard with fine mesh filter, vacuum non-return valve, gas ballast valve, protection cover and oil separator. Flange mounted motors comply with DIN EN 60034, have IP54 protection and insulation class F

### 性能曲線圖 / Performance Curve

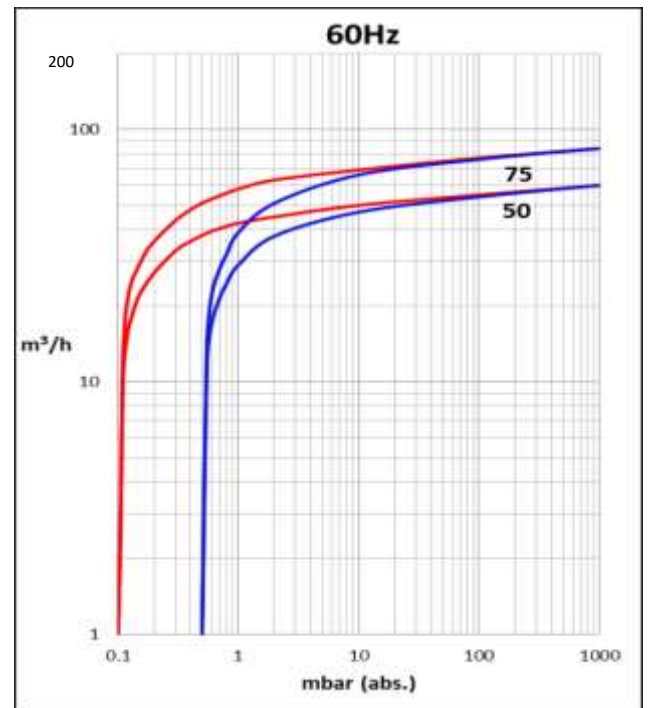
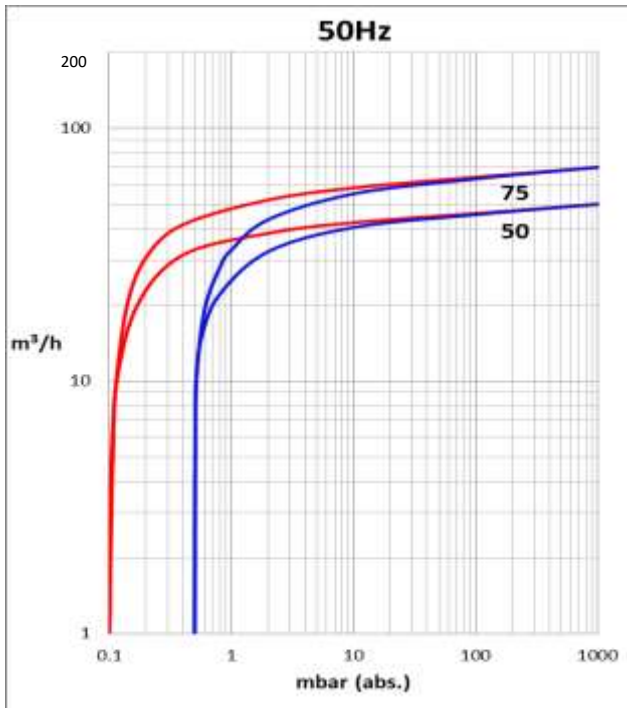

— 無氣鎮閥 without gas ballast  
— 有氣鎮閥 with gas ballast

VO		50		75	
頻率 Frequency	Hz	50Hz	60Hz	50Hz	60Hz
額定流量 Nominal capacity	m <sup>3</sup> /h	50	60	70	84
絕對真空 Ultimate partial pressure	mbar(abs.)	0.1			
電機類型 Motor version	3~	50Hz	200-240 / 346-415 V		
		60Hz	220-275 / 380-480 V		
電機功率 Motor rating	kW	1.25	1.5	1.85	2.2
電流 Current	A	5.7 / 3.3	5.7 / 3.3	7.8 / 4.5	8.2 / 4.7
轉速 Speed	min <sup>-1</sup>	1440	1720	1425	1720
平均噪音值 Average noise level	dB(A)	64	67	64	68
最大重量 Maximum weight	kg	58	58	58	58
油量 Oil capacity	l	3.0		3.0	



# VO - 50 / 75 油潤滑旋片式真空泵 / Oil Lubricated Rotary Vane Vacuum Pump

## 尺寸圖 / Dimensions (mm)

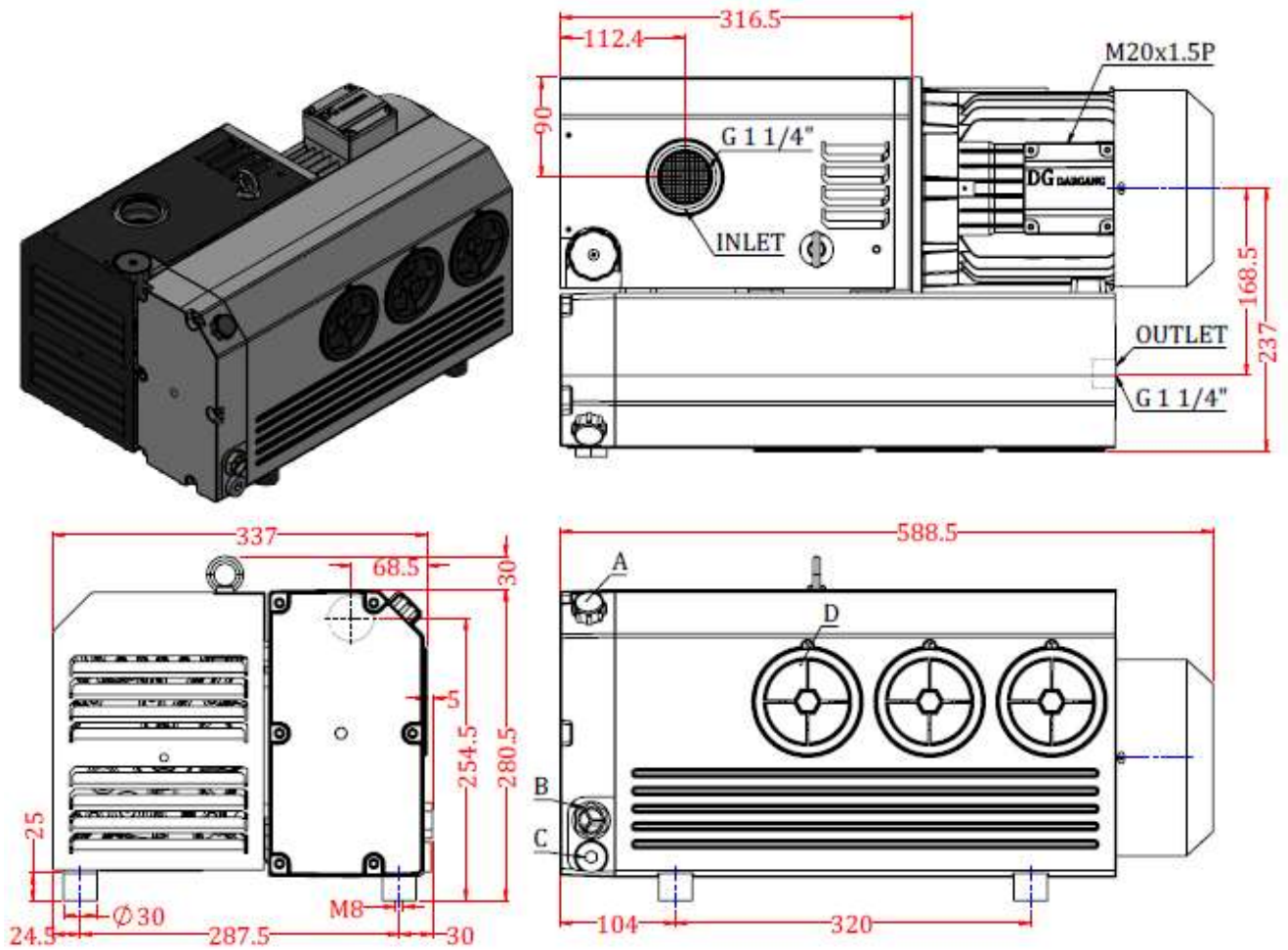

A	注油口 Oil filling point	C	排油口 Oil drain point
B	油位鏡 Oil check	D	油霧分離器 Oil separator

我們保留調整數據的權利，尺寸和電流值會因不同的電機而與數據表不同。  
 We reserve the right to alter technical information. The dimensions and the current drawn can differ when compared with the data list, depending on the motor type.



# VO - 100 / 150 油潤滑旋片式真空泵 / Oil Lubricated Rotary Vane Vacuum Pump

油潤滑旋片式真空泵，流量從 100 至 180 m<sup>3</sup>/hr，絕對真空 0.1mbar（絕對值）。法蘭式電機，轉子兩側裝有軸承及空氣冷卻，內置過濾篩網，真空逆止閥，氣鎮閥，保護罩和油氣分離器。葉片採用鋁合金材質，壽命長，汽缸兩側採用 O 型密封環。法蘭式電機符合 DIN EN60034，具有 IP54 防護和絕緣等級 F



Oil lubricated rotary vane vacuum pump with capacities ranging from 100 to 180 m<sup>3</sup>/h and an ultimate vacuum of 0.1 mbar (abs.). Flange motor, bearings on both sides of the rotor, air cooling. Fitted as standard with fine mesh filter, vacuum non-return valve, gas ballast valve, protection cover and oil separator. Flange mounted motors comply with DIN EN 60034, have IP54 protection and insulation class F

## 性能曲線圖 / Performance Curve

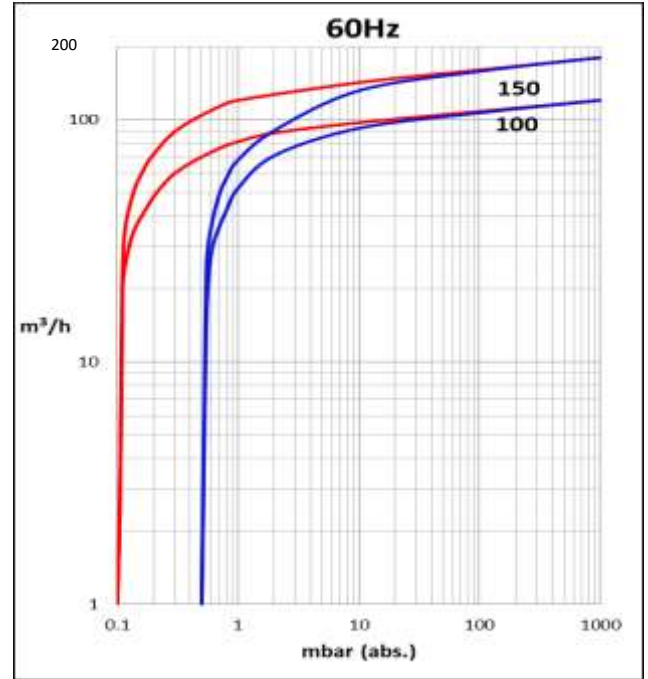
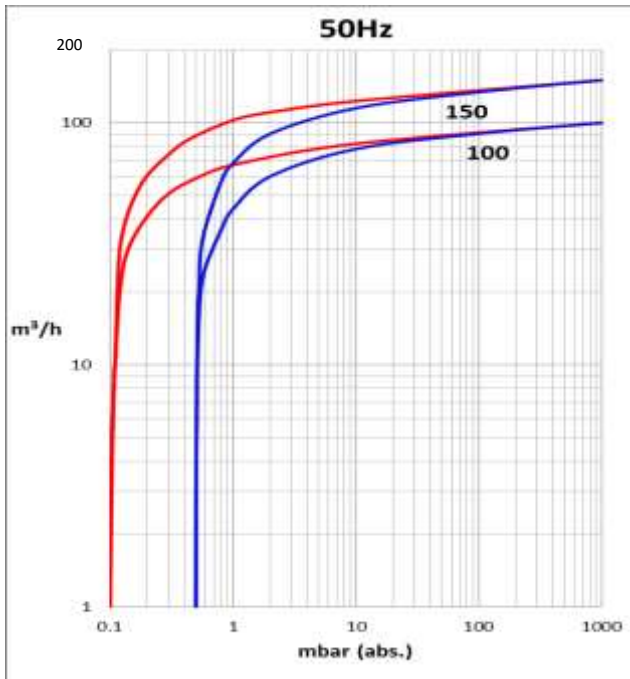

— 無氣鎮閥 without gas ballast  
— 有氣鎮閥 with gas ballast

VO		100		150	
頻率 Frequency	Hz	50Hz	60Hz	50Hz	60Hz
額定流量 Nominal capacity	m <sup>3</sup> /h	100	120	150	180
絕對真空 Ultimate partial pressure	mbar(abs.)	0.1			
電機類型 Motor version	3~	50Hz 200-240 / 346-415 V		60Hz 220-275 / 380-480 V	
電機功率 Motor rating	kW	2.2	2.6	3.0	3.7
電流 Current	A	9.2 / 5.3	9.3 / 5.4	11.8 / 6.80	13.0 / 7.50
轉速 Speed	min <sup>-1</sup>	1460	1745	1440	1720
平均噪音值 Average noise level	dB(A)	66	69	68	71
最大重量 Maximum weight	kg	90	90	90	90
油量 Oil capacity	l	3.0		3.5	



# VO - 100 / 150 油潤滑旋片式真空泵 / Oil Lubricated Rotary Vane Vacuum Pump

## 尺寸圖 / Dimensions (mm)

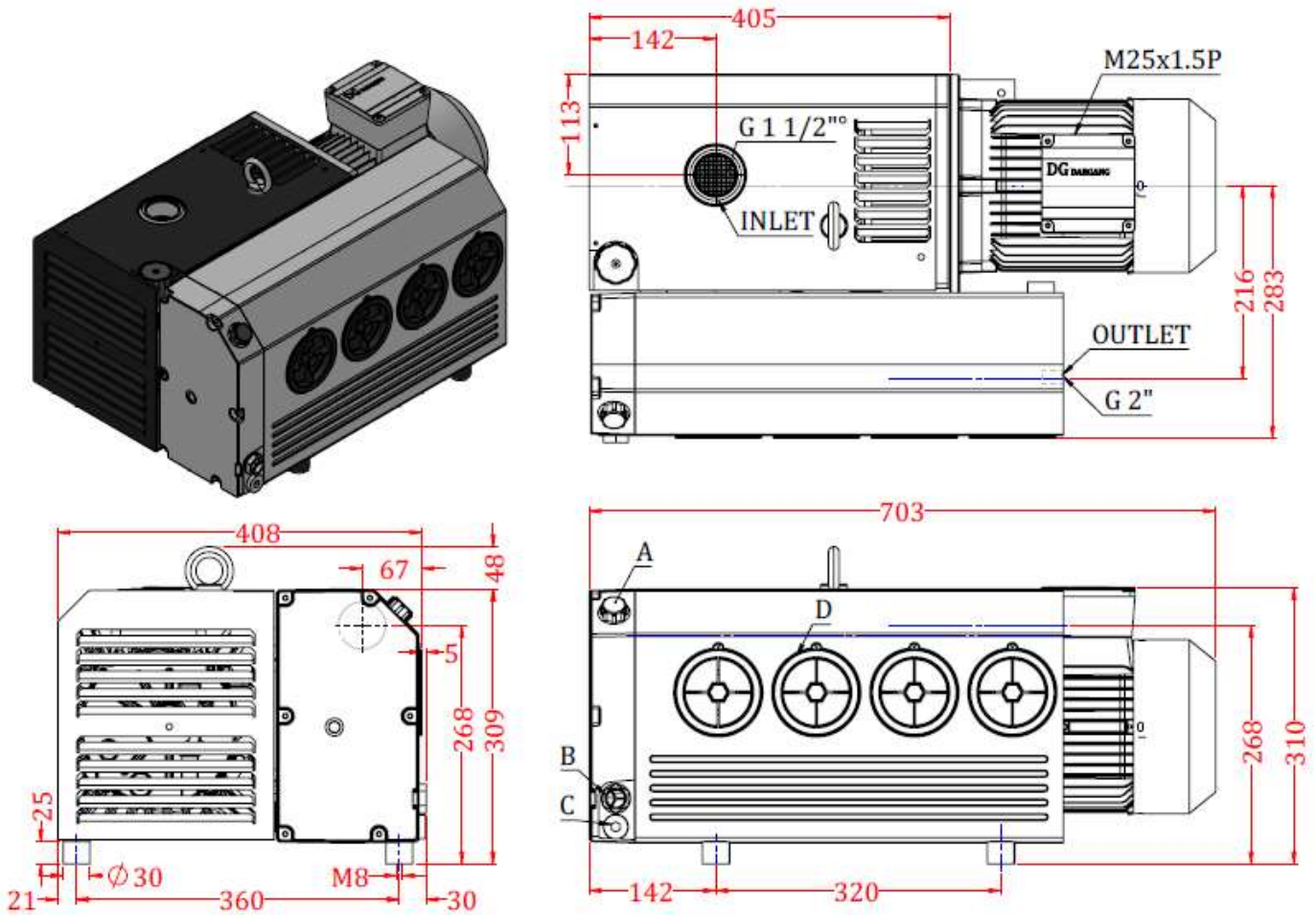

A	注油口 Oil filling point	C	排油口 Oil drain point
B	油位鏡 Oil check	D	油霧分離器 Oil separator

我們保留調整數據的權利，尺寸和電流值會因不同的電機而與數據表不同。  
 We reserve the right to alter technical information. The dimensions and the current drawn can differ when compared with the data list, depending on the motor type.



## VO - 200 / 300 油潤滑旋片式真空泵 / Oil Lubricated Rotary Vane Vacuum Pump

油潤滑旋片式真空泵，流量從 200 至 360 m<sup>3</sup>/hr，絕對真空 0.1mbar（絕對值）。法蘭式電機，轉子兩側裝有軸承及油／氣熱交換器，內置過濾篩網，真空逆止閥，氣鎮閥，保護罩和油氣分離器。葉片採用鋁合金材質，壽命長，汽缸兩側採用 O 型密封環。法蘭式電機符合 DIN EN60034，具有 IP54 防護和絕緣等級 F



Oil lubricated rotary vane vacuum pump with capacities ranging from 200 to 360 m<sup>3</sup>/h and an ultimate vacuum of 0.1 mbar (abs.). Flange motor, bearings on both sides of the rotor, oil/air heat exchanger. Fitted as standard with fine mesh filter, vacuum non-return valve, gas ballast valve, protection cover and oil separator. Flange mounted motors comply with DIN EN 60034, have IP54 protection and insulation class F

### 性能曲線圖 / Performance Curve

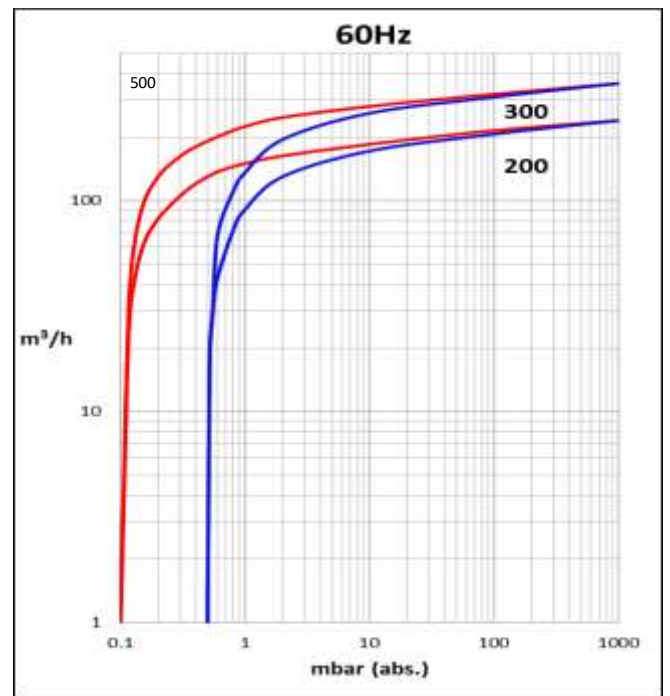
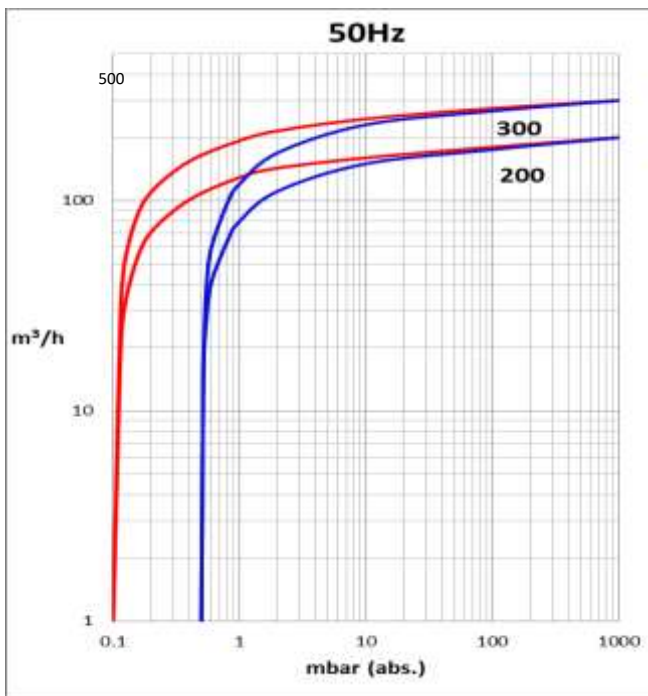

— 無氣鎮閥 without gas ballast  
— 有氣鎮閥 with gas ballast

VO		200		300	
頻率 Frequency	Hz	50Hz	60Hz	50Hz	60Hz
額定流量 Nominal capacity	m <sup>3</sup> /h	200	240	300	360
絕對真空 Ultimate partial pressure	mbar(abs.)	0.1			
電機類型 Motor version	3~	50Hz 200-240 / 346-415 V 60Hz 220-275 / 380-480 V			
電機功率 Motor rating	kW	5.5	6.3	7.5	8.6
電流 Current	A	20.5 / 11.9	21.4 / 12.3	28.3 / 16.4	29.0 / 16.8
轉速 Speed	min <sup>-1</sup>	1470	1760	1470	1760
平均噪音值 Average noise level	dB(A)	69	73	70	74
最大重量 Maximum weight	kg	179	179	182	182
油量 Oil capacity	l	8		8	





# VO - 200 / 300 油潤滑旋片式真空泵 / Oil Lubricated Rotary Vane Vacuum Pump

## 尺寸圖 / Dimensions (mm)

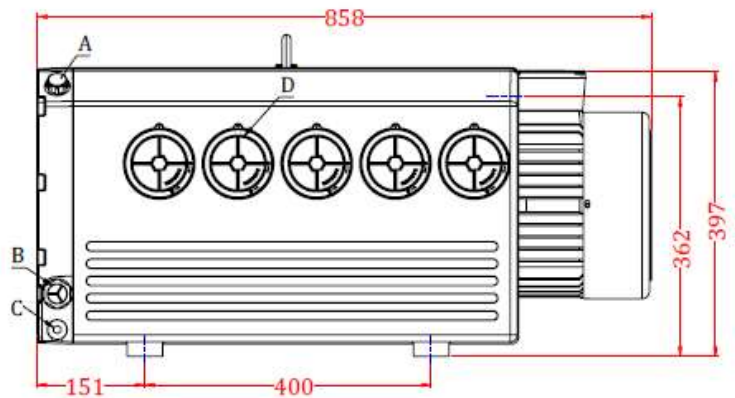
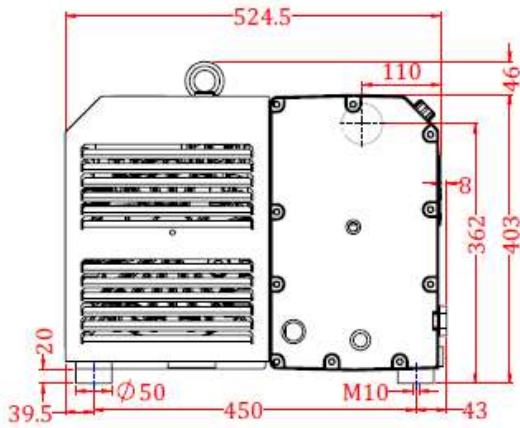
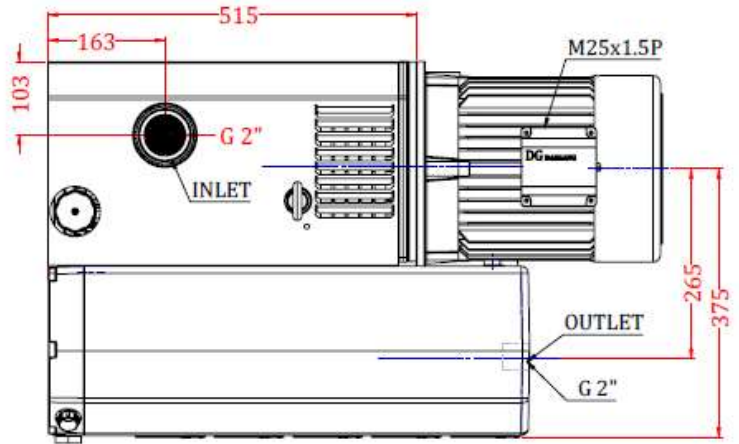
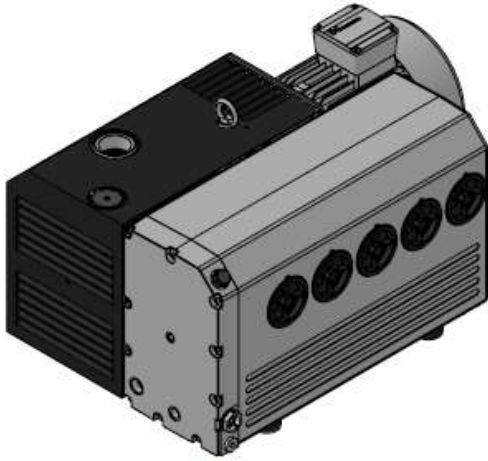

A	注油口 Oil filling point	C	排油口 Oil drain point
B	油位鏡 Oil check	D	油霧分離器 Oil separator

我們保留調整數據的權利，尺寸和電流值會因不同的電機而與數據表不同。  
 We reserve the right to alter technical information. The dimensions and the current drawn can differ when compared with the data list, depending on the motor type.



入口過濾器 / Suction filter

VF Series 尺寸圖 / Dimensions (mm)

型號/Type	m <sup>3</sup> /h	R	A	B	C	D	重量 KG	材質( material ) / 精度( accuracy)
VF-06	45	G 3/4"	102	95	57	51	0.6	紙濾心(Paper filter) / 20um
VF-10	100	G 1 1/4"	146	116	82	70	1.4	紙濾心(Paper filter) / 20um
VF-12	200	G 1 1/2"	190	195	110	109	2.3	紙濾心(Paper filter) / 20um
VF-16	360	G 2"	220	265	118	130	4.5	紙濾心(Paper filter) / 20um
VF-20	360	G 2 1/2"	220	265	118	130	4.5	紙濾心(Paper filter) / 20um

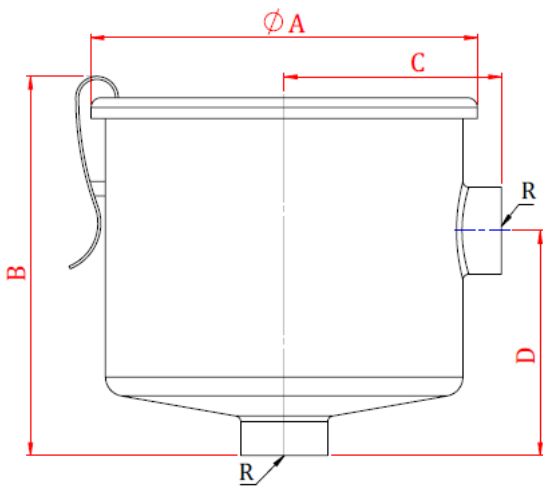

油霧過濾器 / Oil separator

型號 / Type	A	適用機型/ Applicable models
VO- 20-018	128 (Fig.1)	VO-20
VO-150-018	102 (Fig.2)	VO-50,75,100,150
VO-300-018	152 (Fig.2)	VO-200,300

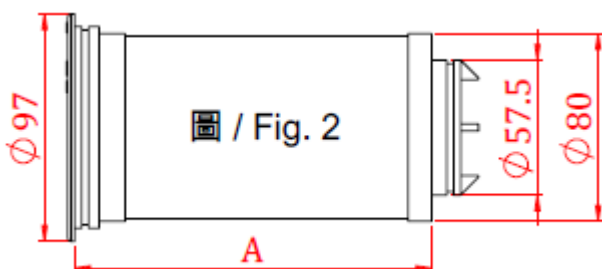
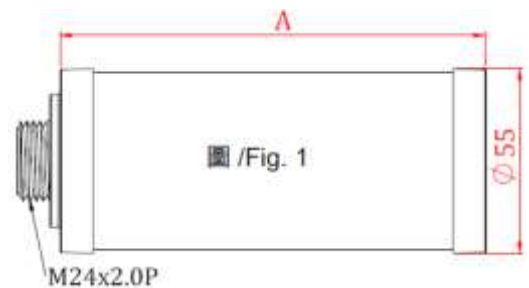



逆止閥 / Non-return valve

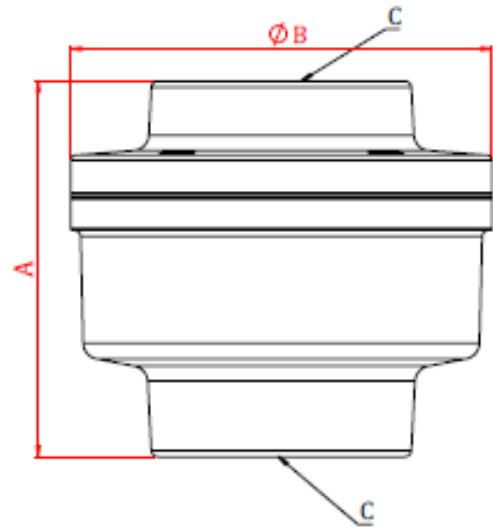

尺寸圖 / Dimensions (mm)

型號 / Type	A	B	C
NRV-03	88	105	G 1 1/4"
NRV-04	88	105	G 1 1/2"
NRV-05	116	130	G 2"

防震腳墊 / Footprint dimensions [mm]

型號 Type	D	H	G	L
MFB2520	25	20	M6	12
MFB3025	30	25	M8	15
MFB5020	50	20	M10	20
MFB7545	75	40	M12	20

